

J.R.BOONE

HORIZONTAL HELICAL BLADE MIXERS

50 - 10,000 litres



**WORLDWIDE
MIXING
SPECIALISTS**

REDUCED MIXING TIMES

DIVERSE MIXING

PROCESS ADAPTABILITY

EFFICIENT DISCHARGE

MINIMUM MAINTENANCE

BATCH OR CONTINUOUS

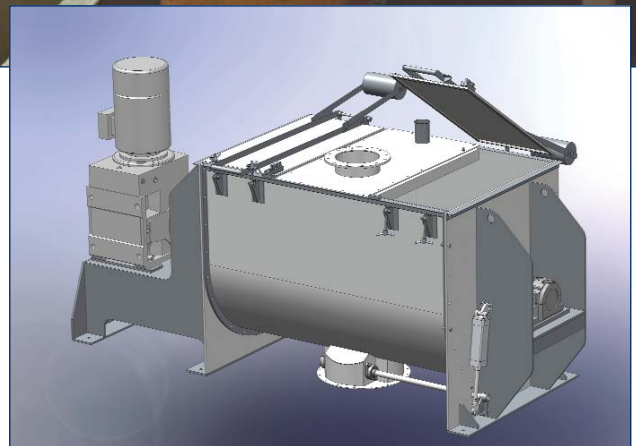

J.R.Boone Ltd

18 Silk Street, Congleton
Cheshire, CW12 4DH, England
tel: +44 (0)1260 272894
www.jrboone.com
sales@jrboone.com

**Design, manufacture and installation.
Mixing and blending specialists.**

J.R. BOONE

HORIZONTAL HELICAL BLADE MIXERS

50 - 10,000 litres

The J.R.Boone HHBM - 50 to 500 litres

Model	Working capacity	Overall length	Overall width	Overall height		Trough Clearance
	Max Capacity Litres			A (mm)	B (mm)	
50	50	1600	440	850	1070	410
100	100	1770	540	940	1250	410
150	150	1920	605	1010	1300	410
200	200	2370	685	1070	1400	410
300	300	2430	770	1160	1550	410
400	400	2540	830	1250	1650	410
500	500	2750	890	1270	1700	410

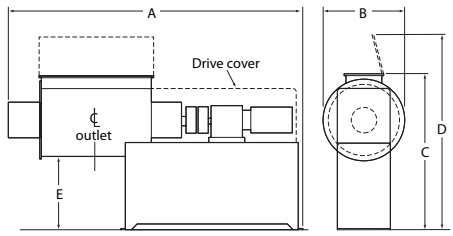

The J.R.Boone HHBM - 750 to 3000 litres

Model	Working capacity	Overall length	Overall width	Overall height		Trough Clearance
	Max Capacity Litres			A (mm)	B (mm)	
750	750	2730	1040	1430	2000	380
1000	1000	2975	1150	1540	2100	380
1250	1250	3290	1220	1600	2200	380
1500	1500	3600	1290	1670	2260	380
2000	2000	3760	1400	1800	2450	380
2500	2500	4280	1500	1930	2600	380
3000	3000	4420	1600	2010	2750	380

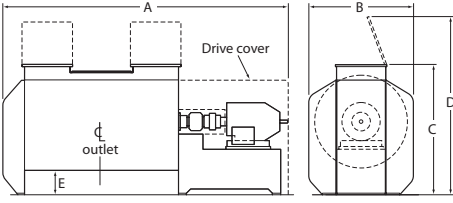

The J.R.Boone HHBM - 4000 to 10000 litres

Model	Working capacity	Overall length	Overall width	Overall height		Trough Clearance
	Max Capacity Litres			A (mm)	B (mm)	
4000	4000	4000	1850	2160	2750	400
5000	5000	5500	2000	2300	3100	400
7500	7500	5850	2260	2600	3550	400
10000	10000	6400	2450	2800	3750	400

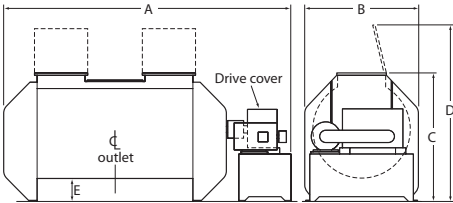

Overall dimensions may vary according to clients process requirements. Drive size to be confirmed on application.

The discharge outlet is positioned midway along the trough, its type selected to meet process requirements.

Owing to our continual development, JR Boone reserve the right to amend the figures and dimensions given without prior notice.

Horizontal Mixers

Efficient - using an optimised mixing action to fully and uniformly mix, in the shortest time possible.

Easy to clean - made possible with our clean arm attachment and minimum number mixing paddles.

Versatile - J.R.Boone offer a range of mixers that handle dry or damp powders, pastes, slurries and liquids.

Extras - with a full list of optional equipment that allow the mixers to extend their processing capabilities.

In-house - fully designed and manufactured in-house at our facilities in Cheshire.

Safety: CE Compliance - all machines comply with EC Machinery Directive 2006/42/EC. Machines and mixing systems can also be supplied in accordance with ATEX, PED, and other EC Directives.

Testing - in-house test facilities.

Hire - machines available, information on request.



Dry cell battery powders
 Ready mixed tile adhesive
 Mayonnaise and seafood mixes
 Cake mixes
 Catering recipes
 Fine chemical powder mixing
 Powdered soup mixes
 Pre extrusion breakfast cereals
 Powdered drinks



J.R.Boone Ltd

18 Silk Street, Congleton
 Cheshire, CW12 4DH, England
 tel: +44 (0)1260 272894
 www.jrboone.com
 sales@jrboone.com